

FIG. 6 Caliper, Shield, and Rotor Assemblies—Disc Brakes, Front—Mark VII/Continental, Mustang SVO

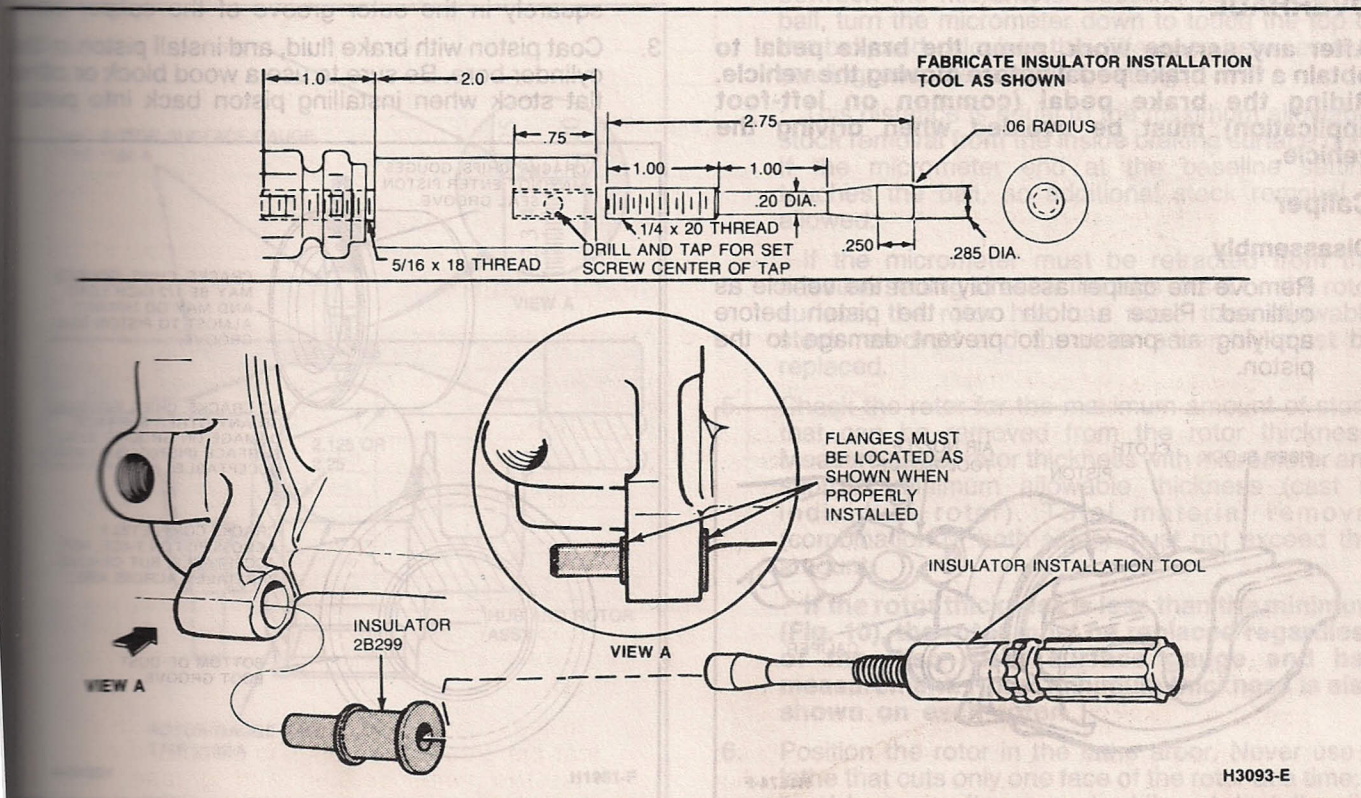

FIG. 7 Insulator and Sleeve Installation