

**HONDALINE<sup>®</sup>**

**INSTRUCTION MANUAL**  
**FAIRING KIT FOR V65 SABRE (VF1100S)**

**MANUEL D'INSTRUCTION**  
**KIT DE MONTAGE DV CARENAGE DE LA SABRE**  
**V65 (VF1100S)**

**'84**

# **V65 SABRE FAIRING KIT VF1100S**

**NOTE:** This fairing kit is especially designed for VF1100S.

The following steps are necessary to install this kit on your motorcycle: 1) Re-routing of the headlight circuits and 2) Adjustment and inspection of the installation.

Improper installation or adjustment of any of the above may create an unsafe vehicle. In order to prevent improper installation, we strongly urge you to have the kit installed by your Honda Dealer.

## PARTS LIST

Index No.	Parts Name	Q'ty	Index No.	Parts Name	Q'ty
①	Meter, stay	1	③7	Wind, shield, screen, base	1
②	Sub, wire, harness	1	③8	Nut, flange, 4 mm	2
③	Fuse, plate, cover	1	③9	Nut, plate, wind, shield screen, screw	2
④	Coupler, holder	1	④0	Cap, wind, shield, screen	8
⑤	Collar $\phi 6$ mm ( $\ell = 4$ mm, white)	2	④1	Screw, 4 x 13 mm, wind, shield screen	4
⑥	Bolt, flange, 6 x 12 mm	2	④2	Collar, wind, shield, screen $\phi 4$ mm ( $\ell = 9$ mm)	4
⑦	Coupler, holder, cover	1	④3	Screw, 4 x 8 mm, wind, shield screer	4
⑧	Fairing, assy	1	④4	Washer, plain, 4 mm	4
⑨	Plain, washer, 8 mm	2	④5	Bolt, flange, 8 x 80 mm	1
⑩	Bolt, stay, 14 x 25 mm	2	④6	Collar, leg, shield, set $\phi 6$ mm ( $\ell = 8$ mm, black)	2
⑪	Bolt, flange, 8 x 14 mm	2	④7	Collar, setting $\phi 6$ mm ( $\ell = 13$ mm, black)	4
⑫	Bolt, cowl, stay, setting	1	④8	Pillar, R	1
⑬	Plate, cowl, stay, setting	1	④9	Pillar, L	1
⑭	Brkt, R, fairing, side stay	1	⑤0	Bolt, SPL, 6 x 16 mm	2
⑮	Bolt, flange, 8 x 18 mm	1	⑤1	Band, leg, shield, stay	2
⑯	Nut, flange, 6 mm	4	⑤2	Pad, R, pillar	1
⑰	Screw, leg, shield, setting 6 x 14 mm	6	⑤3	Pad, L, pillar	1
⑱	Collar, rear, fender $\phi 6$ mm ( $\ell = 3.5$ mm, black)	4	⑤4	Screw, washer, 4 x 12 mm	4
⑲	Cap, leg, shield	6	⑤5	Nut, HEX, 6 mm	2
⑳	Collar, L, stay, RR $\phi 8$ mm ( $\ell = 63$ mm)	1	⑤6	Screw, tapping, 4 x 20 mm	2
㉑	Leg, shield, R	1	⑤7	Brkt, R, horn	1
㉒	Leg, shield, L	1	⑤8	Brkt, L, horn	1
㉓	Tape, harness, cover	1	⑤9	Wire, clip	1
㉔	Nut, cap, 6 mm	6	⑥0	Harness, clip	1
㉕	Washer, plain 6 mm	2	⑥1	Clip (white)	1
㉖	Leg, shield, bracket, R	1	⑥2	Band, B3, wire (AL)	4
㉗	Leg, shield, bracket, L	1	⑥3	Band, wire, harness (black)	1
㉘	Brkt, R, FR, leg, shield	1	⑥4	Rubber, leg, shield	2
㉙	Brkt, L, FR, leg, shield	1	⑥5	Bolt, SPL, 6 x 22 mm	4
㉚	Nut, plate, 6 mm	2	⑥6	Bolt, flange, 8 x 22 mm	2
㉛	Rear, view, mirror, R	1	⑥7	Pillar, R, cover	1
㉜	Rear, view, mirror, L	1	⑥8	Pillar, L, cover	1
㉝	Screw, paw, head, 6 x 28 mm	4	⑥9	Screw, tapping, (PO) 4 x 12 mm	2
㉞	Washer, plain, 6 mm	4	⑦0	Brkt, twoway, joint	2
㉟	Collar, $\phi 6$ mm, ( $\ell = 5$ mm black)	4	⑦1	Screw, washer, 5 x 10 mm	2
㊱	Wind, shield, screen	1	⑦2	Bolt, flange, 8 x 25 mm	2
			⑦3	Nut, flange 8 mm	2
			⑦4	Bolt, flange, 8 x 16 mm	2

<b>HONDALINE</b>	Accessory <b>'84 SUB INSTRUCTION MANUAL</b>	Application <b>V65 SABRE (VF1100S)</b>	Publications No. <b>HP 296 8402</b>
			Issue Date <b>FEBRUARY 1984</b>

The following is a table of Fairing Kit index numbers and Kit pack numbers. Please refer to the details listed below in attaching the Kit.

**TABLE**

INDEX No	KIT PACK No	Parts Name	Q'ty	INDEX No	KIT PACK No	Parts Name	Q'ty
①	S-②	Meter, stay	1	③7	P	Wind, shield, screen, base	1
②	P	Sub, wire, harness	1	③8	A-④8	Nut, flange, 4 mm	2
③	S-⑥	Fuse, plate, cover	1	③9	C-③8	Nut, plate, wind, shield screen, screw	2
④	S-①	Coupler, holder	1	④0	P	Cap, wind, shield, screen	8
⑤	A-⑨0	Collar $\phi$ 6 mm ( $\ell$ = 4 mm, white)	2	④1	B-④2	Screw, 4 x 13 mm, wind, shield screen	4
⑥	B-⑨1	Bolt, flange, 6 x 12 mm	2	④2	A-④3	Collar, wind, shield, screen $\phi$ 4 mm ( $\ell$ = 9 mm)	4
⑦	S-③	Coupler, holder, cover	1	④3	B-④4	Screw, 4 x 8 mm, wind, shield screen	4
⑧		Fairing, assy	1	④4	A-④9	Washer, plain, 4 mm	4
⑨	C-⑫	Plain, washer, 8 mm	2	④5	B-⑨3	Bolt, flange, 8 x 80 mm	1
⑩	B-⑤4	Bolt, stay, 14 x 25 mm	2	④6	A-⑦0	Collar, leg, shield, set $\phi$ 6 mm ( $\ell$ = 8 mm, black)	2
⑪	B-⑦6	Bolt, flange, 8 x 14 mm	2	④7	A-⑦4	Collar, setting $\phi$ 6 mm ( $\ell$ = 13 mm, black)	4
⑫	C-⑨	Bolt, cowl, stay, setting	1	④8	P	Pillar, R	1
⑬	C-⑩	Plate, cowl, stay, setting	1	④9	P	Pillar, L	1
⑭	C-⑦9	Brkt, R, fairing, side stay	1	⑤0	B-⑦5	Bolt, SPL, 6 x 16 mm	2
⑮	B-⑨4	Bolt, flange, 8 x 18 mm	1	⑤1	C-②2	Band, leg, shield, stay	2
⑯	A-⑥6	Nut, flange, 6 mm	4	⑤2	S-④	Pad, R, pillar	1
⑰	B-⑰	Screw, leg, shield, setting 6 x 14 mm	6	⑤3	S-⑤	Pad, L, pillar	1
⑱	C-⑰	Collar, rear, fender $\phi$ 6 mm ( $\ell$ = 3.5 mm, black)	4	⑤4	A-⑤1	Screw, washer, 4 x 12 mm	4
⑲	P	Cap, leg, shield	6	⑤5	C-⑦1	Nut, HEX, 6 mm	2
⑳	C-⑧0	Collar, L, stay, RR $\phi$ 8 mm ( $\ell$ = 63 mm)	1	⑤6	A-⑤3	Screw, tapping, 4 x 20 mm	2
㉑	P	Leg, shield, R	1	⑤7	S-⑩	Brkt, R, horn	1
㉒	P	Leg, shield, L	1	⑤8	S-⑪	Brkt, L, horn	1
㉓	P	Tape, harness, cover	1	⑤9	S-⑬	Wire, clip	1
㉔	A-⑤8	Nut, cap, 6 mm	6	⑥0	S-⑫	Harness, clip	1
㉕	C-⑰	Washer, plain, 6 mm	2	⑥1	P	Clip (white)	1
㉖	S-⑨	Leg, shield, bracket, R	1	⑥2	P	Band, B3, wire (AL)	4
㉗	S-⑧	Leg, shield, bracket, L	1	⑥3	P	Band, wire, harness (black)	1
㉘	C-⑰	Brkt, R, FR, leg, shield	1	⑥4	P	Rubber, leg, shield	2
㉙	C-⑰	Brkt, L, FR, leg, shield	1	⑥5	B-②6	Bolt, SPL, 6 x 22 mm	4
㉚	C-⑥5	Nut, plate, 6 mm	2	⑥6	B-⑨5	Bolt, flange, 8 x 22 mm	2
㉛	P	Rear, view, mirror, R	1	⑥7	P	Pillar, R, cover	1
㉜	P	Rear, view, mirror, L	1	⑥8	P	Pillar, L, cover	1
㉝	A-④6	Screw, paw, head, 6 x 28 mm	4	⑥9	A-⑤2	Screw, tapping, (PO) 4 x 12 mm	2
㉞	A-⑤0	Washer, plain, 6 mm	4	⑦0	S-⑦	Brkt, twoway, joint	2
㉟	A-④5	Collar, $\phi$ 6 mm, ( $\ell$ = 5 mm black)	4	⑦1	B-⑥8	Screw, washer, 5 x 10 mm	2
㊱	P	Wind, shield, screen	1	⑦2	B-②5	Bolt, flange, 8 x 25 mm	2
				⑦3	A-⑬	Nut, flange 8 mm	2
				⑦4	B-⑨2	Bolt, flange, 8 x 16 mm	2

A (No) (Skinpack ground paper no. A)

B (No) ( " " " no. B)

C (No) ( " " " no. C)

P (Vinyl bag packing; no part number)

S (No) (Skinpack packing)

S (Skinpack packing; no part number)

(No): Part number is recorded on skinpack ground paper.

Fig. 1

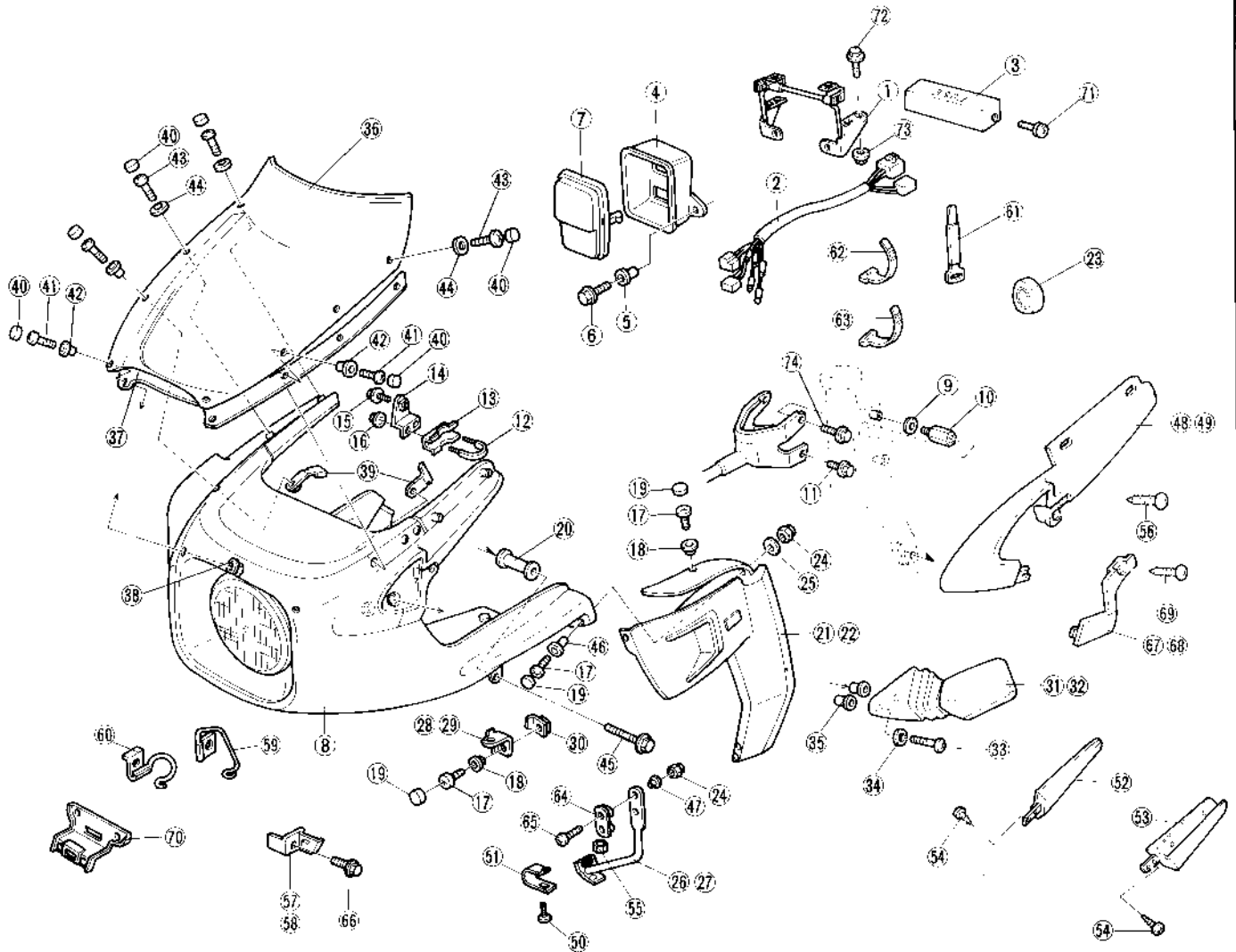

**TOOLS REQUIRED**

- 8 mm, 10 mm, 12 mm and 14 mm spanners or box wrenches
- + and - drivers
- 5 mm and 6 mm socket wrenches
- torque wrench

**TIGHTENING TORQUE**

- Make sure to firmly tighten bolts and screws.
- Specified torque.

Item	Torque Value N-m (kg-m) (ft-lb)
6 mm bolt and nut	8-12 (0.8-1.2) (6-9)
8 mm bolt and nut	18-25 (1.8-2.5) (13-18)
10 mm bolt and nut	30-40 (3.0-4.0) (22-29)
6 mm screw	7-11 (0.7-1.1) (5-8)
8 mm flange bolt and nut	10-14 (1.0-1.4) (7-10)
10 mm flange bolt and nut	30-40 (3.0-4.0) (22-29)
8 mm socket bolt	18-25 (1.8-2.5) (13-18)

- Refer to the Shop Manual for detailed procedures.

## INSTALLATION

- 1) Remove the side cover and then remove the battery and the earth terminal.
- 2) Remove the head light.
  - a. Remove the head light and then remove the coupler connections in the head light case. (Both head light and sensor stay not needed)
  - b. Remove the head light case. (Head light case not needed)
  - c. Remove wires from the meter assembly, the cap nut and the meter. Then, remove the head light case bracket and the R/L turn signal. (Head light case bracket not needed.)

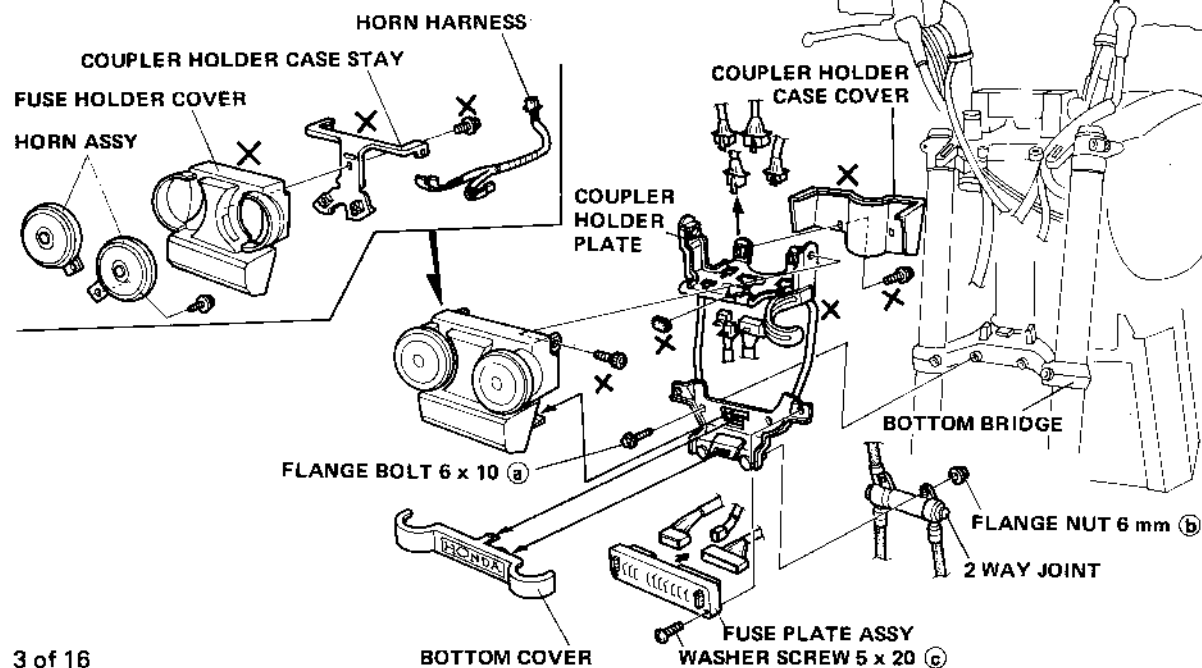
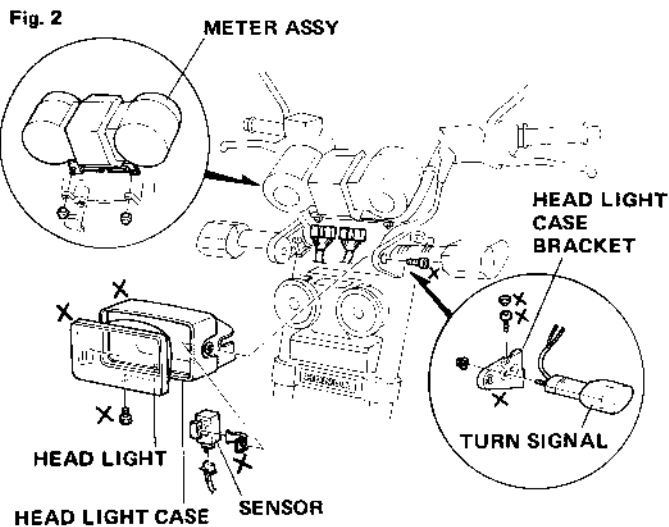

- 3) Remove the horn assembly and the fuse holder cover.
  - a. Remove the bottom cover as shown in Figure 3.  
Note: The bottom cover is held with an upper and a lower (rear side) clicks.
  - b. Remove the screw on the R/L side (upper side) and the lower click to remove the fuse holder and coupler holder case stay as a single unit from the coupler holder plate, and then remove the horn harness. (Fuse holder cover, coupler holder case stay and horn harness not needed.)
  - c. Remove the washer screws 5 x 20 (c) on the fuse plate assembly to remove it from the coupler holder plate, and then remove the connections on the coupler.
  - d. Remove all the connections on the coupler.
  - e. Remove the flange bolt 6 x 10 (a) to remove the coupler holder plate from the bottom bridge. Remove the flange nut 6 mm (b) to remove the two-way joint. (Coupler holder plate and coupler holder case cover not needed.)

- 4) Housing of harness around the front.
  - a. Insert, as shown in Fig. 4, the main harness through the bottom hole of the coupler holder ④ and take out the fuse plate harness and the meter assembly harness through the upper hole, and wind the vinyl tape ②③ on the part of the cord with not shielding tube as shown in Fig. 4-a.
  - b. Wind the vinyl tape on the part of the cord, with no shielding tube, of the speedometer harness, as shown in Fig. 4-b.
  - c. Insert the R/L handle switch harness and the ignition switch harness into the upper hole on the coupler holder ④, and insert the speedometer harness and the sub-harness ② into the bottom hole. Connect two sensors.

Fig. 4

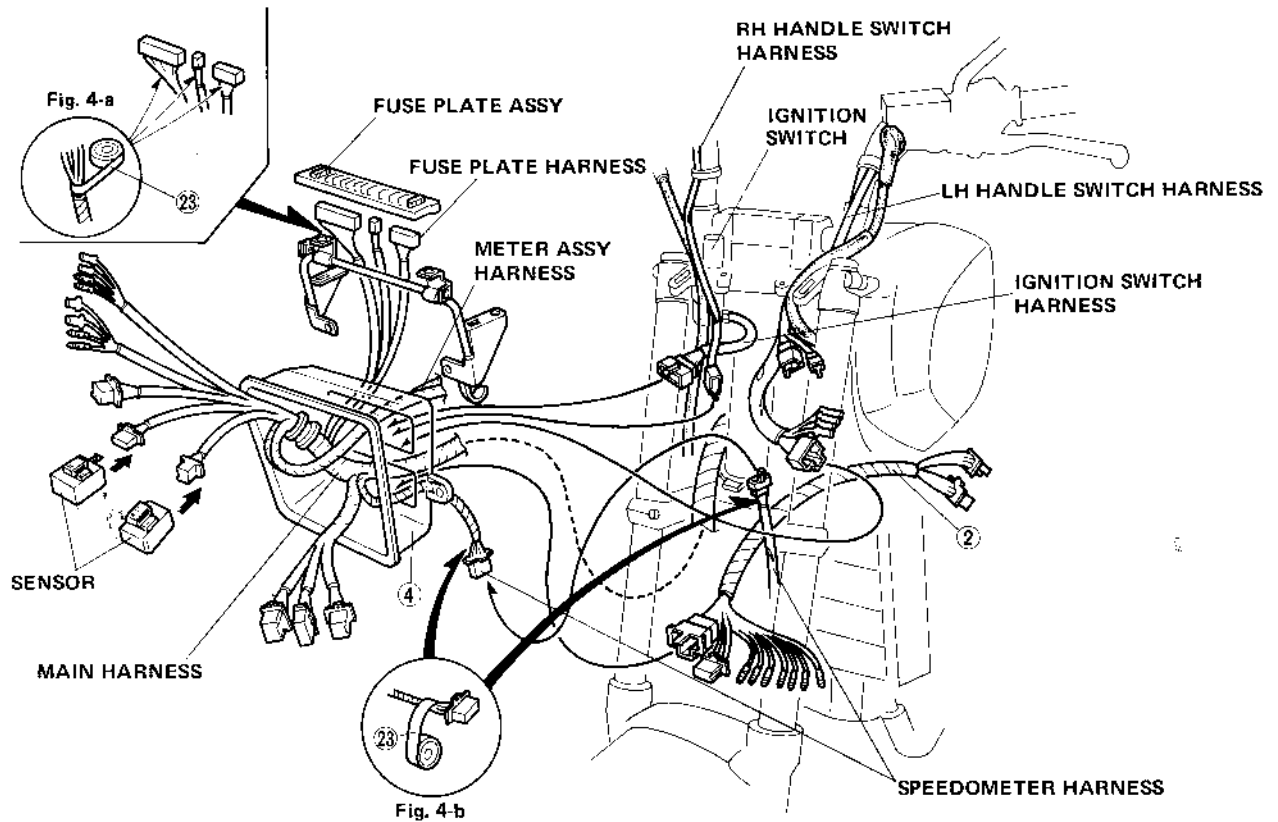

5) Installation of the coupler holder ④ .

- a. Move, as shown in Fig. 5, the brake hose to the outer side from the inner side of the top bridge.
- b. As shown in Fig. 5, Connect the harness to the fuse plate assembly, and install the coupler holder stay ① with the washer screws 5 x 20 ③ removed as shown in Fig. 3.

Note: Insert the harness through the upper part of the coupler holder stay ① .

- c. Install the coupler holder ④ on the top bridge, as shown in Fig. 5-a, with two flange bolts ⑦ 8 x 25 and two flange nuts ⑧ 8 mm.

- d. Install the meter assembly and connect the harness.

- e. Install the coupler holder ④ on the coupler holder stay ① , as shown in Fig. 5, with two collars 6 mm (diameter) x 4 mm (length), white, ⑤ and two flange bolts ⑥ 6 x 12.

- f. Connect the couplers with the corresponding connectors in the coupler holder ④ according to their shape and color.

Note: The brown connector on the sub-harness ② is not needed to be connected.

Tighten the bolts and the nuts with the respectively specified torques.

Fig. 5

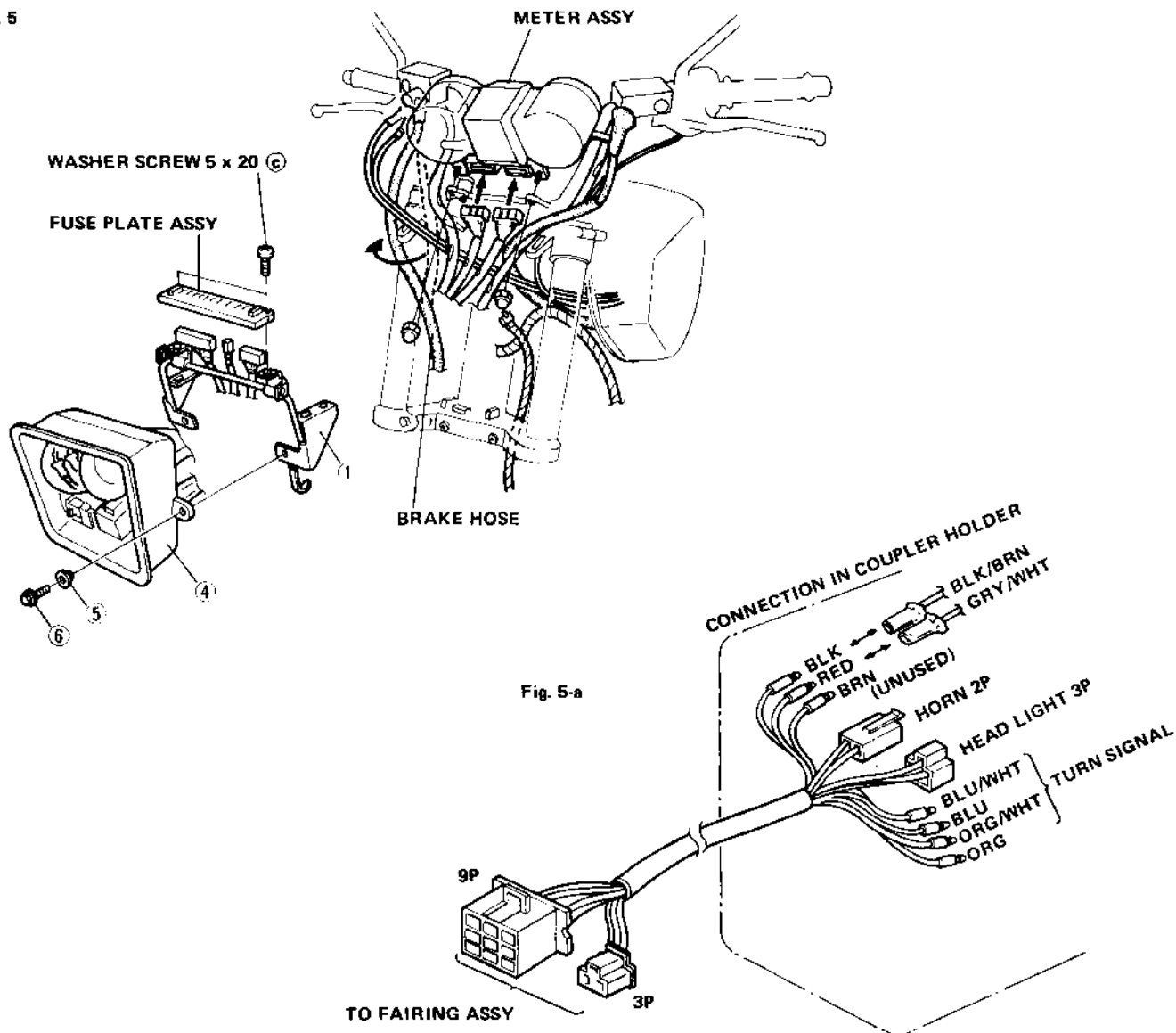

6) Housing of the harness

a. Install the coupler holder on the top bridge, as shown in Fig. 6-a, with two flange bolts ⑦② 8 x 25 and two flange nuts ⑦③ 8 mm.

b. Install the fuse plate cover ③ on the fuse plate assembly installed under (5) , as shown in Fig. 6, with two washer screws ⑦① 5 x 10.

Note: The cover holder of the fuse plate cover ③ is not needed.

c. Check again the connections inside the coupler holder ④ , arrange the harnesses and install the coupler holder cover ⑦ .

Note: Take care, when installing the coupler holder cover ⑦ , so that it will not bite the harnesses.

7) Installation of the two-way joint

a. Firmly clamp the brake hose and the speedometer harness, as shown in Fig. 7-a/b, with the clip on the coupler holder stay ① , and fix the speedometer harness on the front fork with the clip ⑥① white.

b. Install the two-way joint stay ⑦⑩ on the two-way joint with the two flange nuts 6 mm (removed in Fig. 3), and then install the assembly on the bottom bridge with the two flange bolts ①② 6 x 10 (removed in Fig. 3).

Note: Position the speedometer harness as shown in Fig. 7-c.

c. Install the bottom cover on the two-way joint stay ⑦⑩ as shown in Fig. 7.

Fig. 6

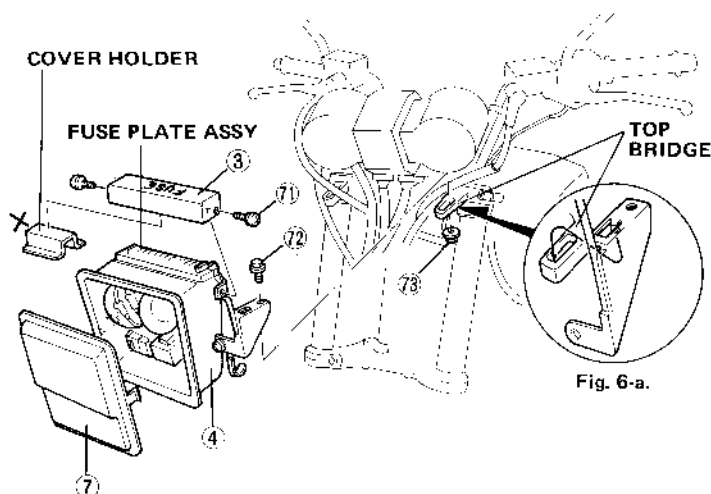
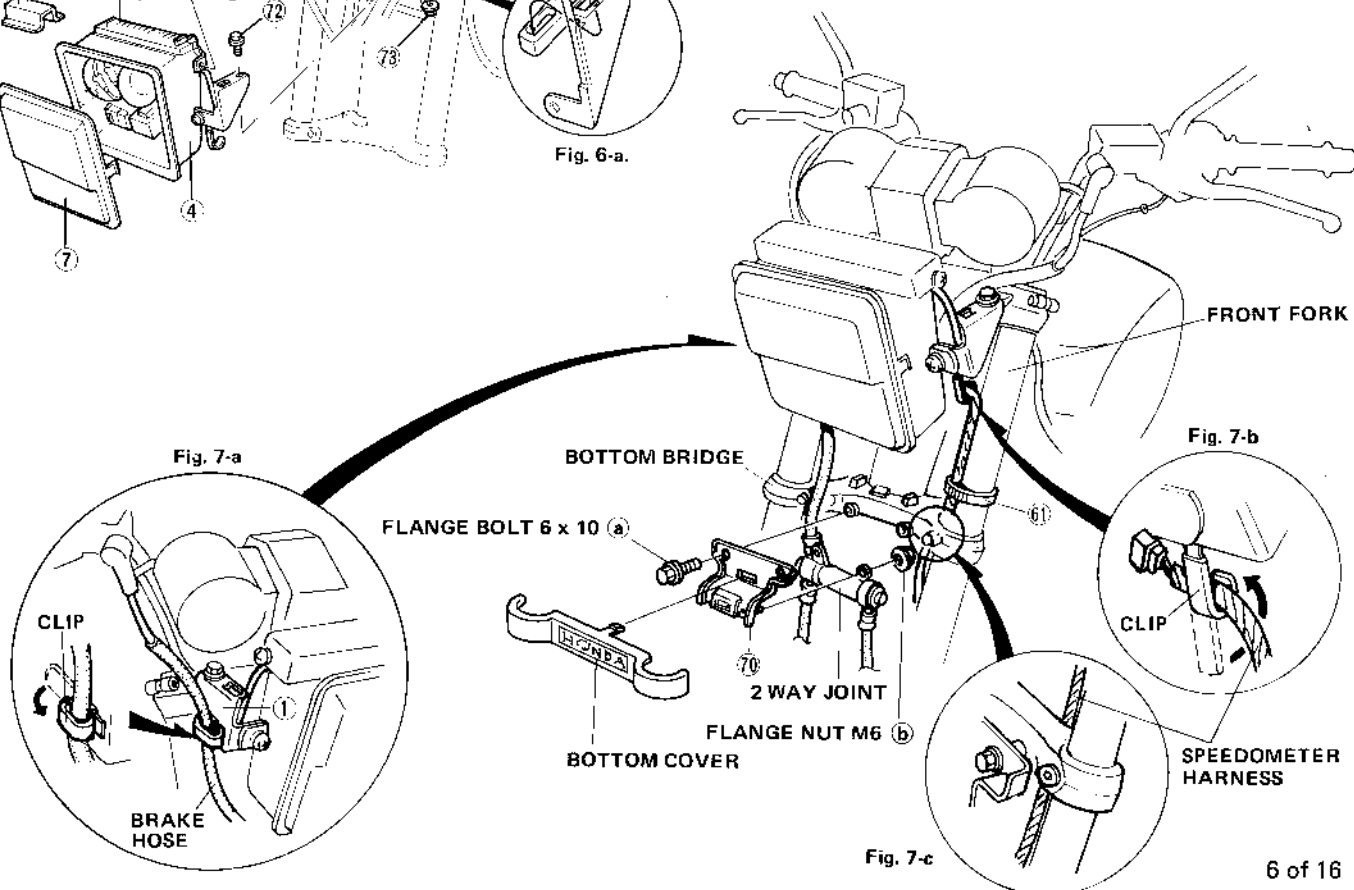

Fig. 7



- 8) Installation of the front turn signal
- Install the front turn signal assembly removed in Fig. 2 on the fairing assembly ⑧, as shown in Fig. 8-a, with a flange nut 10 mm.
  - As shown in Figs. 8 and 8b/c, fix the turn signal harness with the bands in the fairing assembly ⑧, and connect it with the harness of the fairing assembly.

Fig. 8-a

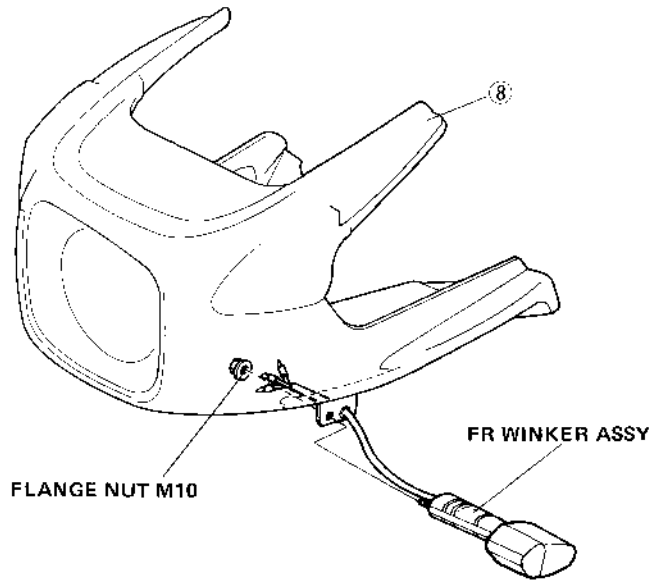
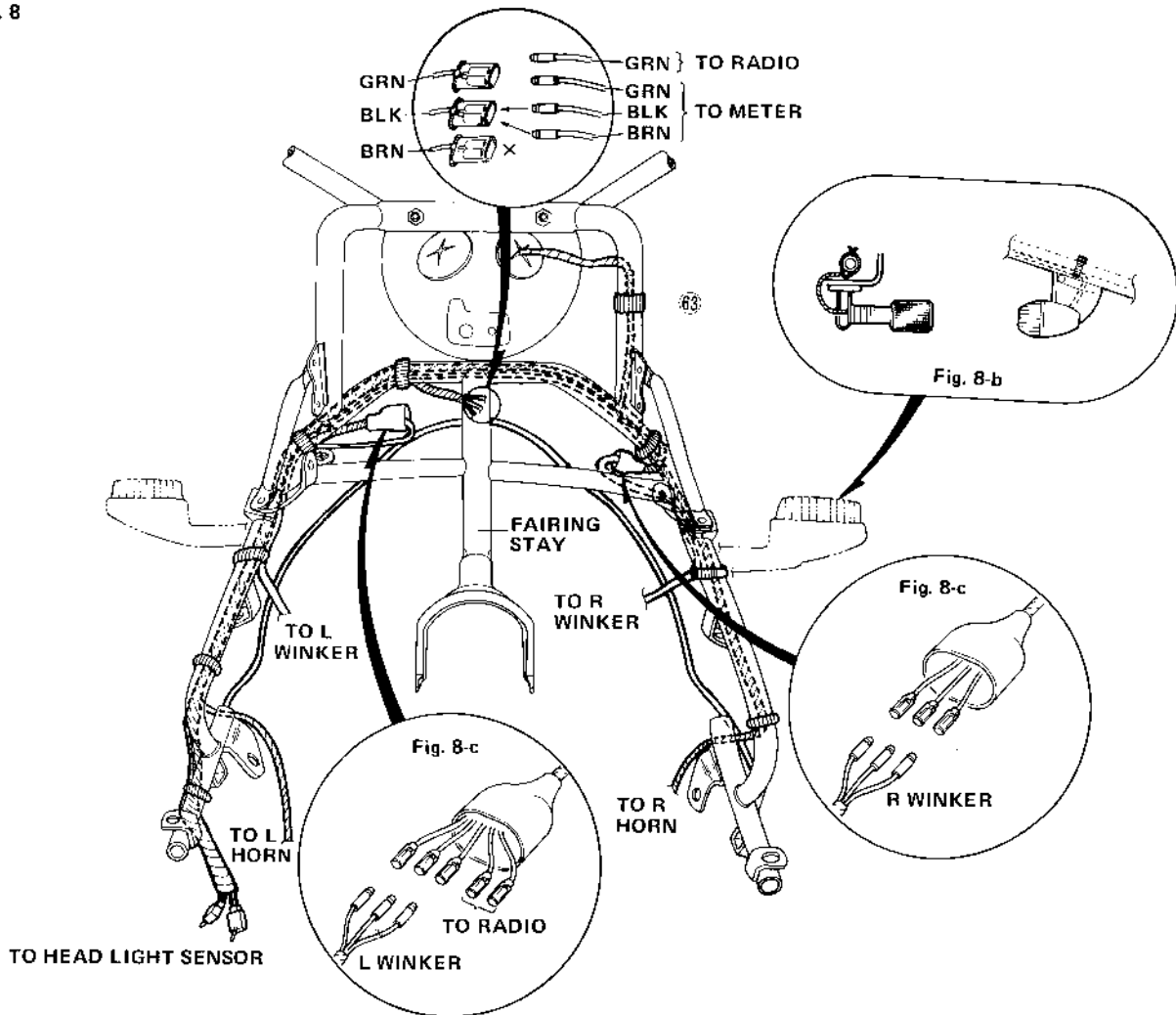
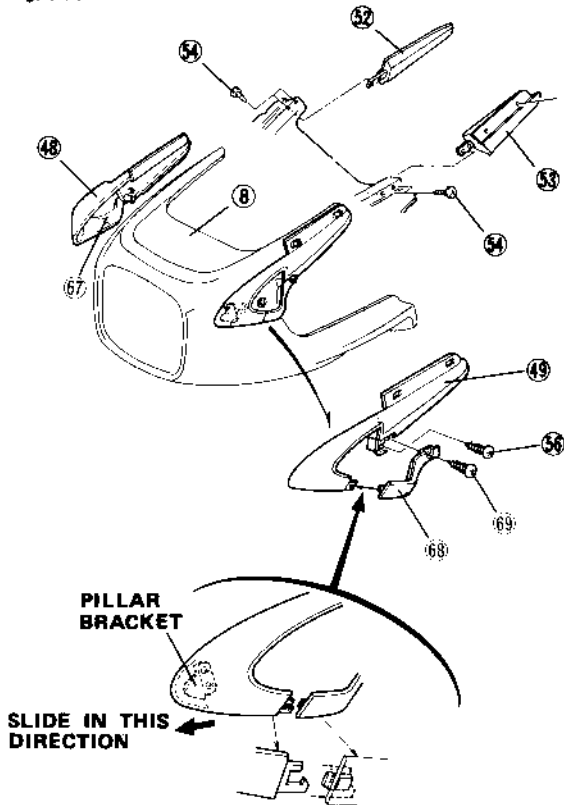

Fig. 8



- 9) Install the rear view mirrors 31 and 32 and windshield screen 36 .
- a. Position the right and left side pillars pad 52 and 53 on the fairing 8 and install using the two 4 x 12 mm screws 54 for each.

Fig. 9-A



- b. Position the rear view mirrors 31 and 32 on the fairing assembly 8 and install using the two 6 x 28 mm pan head screws 33 and 6 mm plain washers 34 for each as shown in Fig. 9-B.

Fig. 9-B

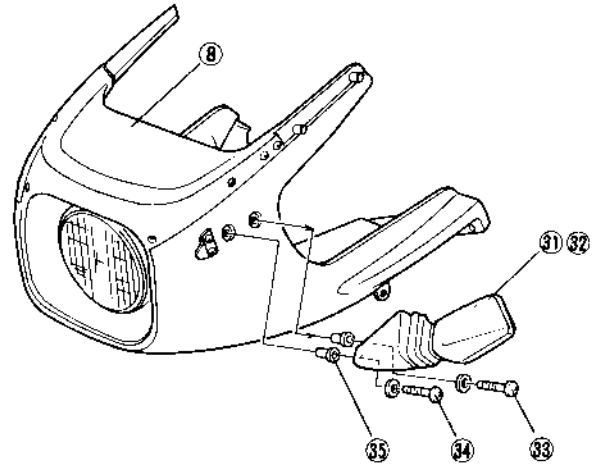

- c. Position the pillars 48 and 49 and pillar covers 67 and 68 on the fairing around the mirror brackets as shown in Fig. 9-C, and install using the hardware shown.

Fig. 9-C

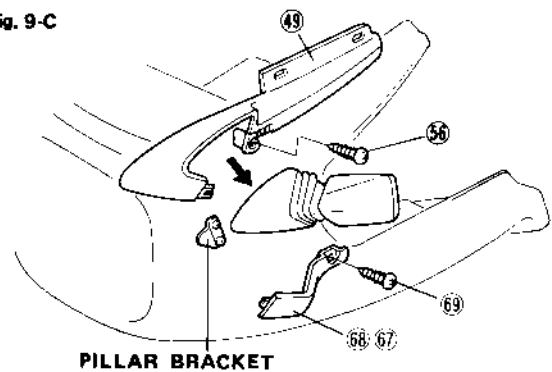

- d. Remove the right and left fairing pockets from inside the fairing. Position the screen base (37) and screen (36) on the fairing and install using the 6 x 9 mm collars (42), 4 x 13 mm screws (41), caps (40) and 4 mm flange nuts (38) at the front four holes (2 on each side), and 4 mm plain washers (44), 4 x 8 mm screws (43) and caps (40) at the rear four holes (2 on each side) as shown in Fig. 9-D.

NOTE: Tighten the screws and caps to the specified torques.

Fig. 9-D

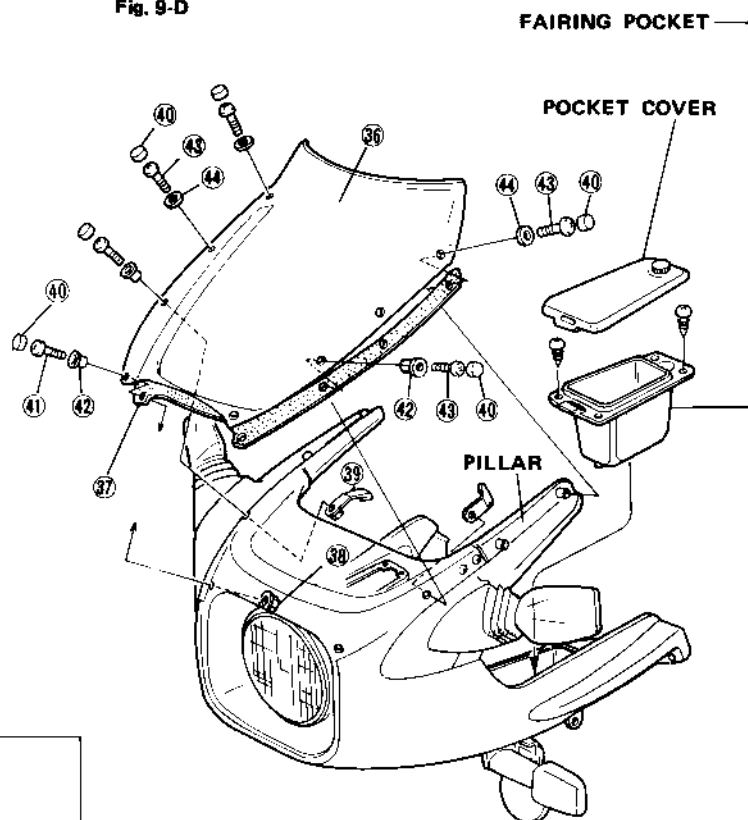

10) Installation of the fairing assembly (8) on the car

At the time of installation of the fairing assembly, cover the radiator side cover with cloth etc. so that it will not be damaged.

- a. Remove the four flange bolts (a), the main harness clip (b) and the throttle cable clip (c) on the rear side of the head pipe of the unit as shown in Fig. 10.

(Bolt (a) and clips (b) and (c) not needed.)

- b. Install, as shown in Fig. 10, two plane washers (9) 8 mm and two stay bolts (10) 14 x 25 on the head pipe installation holes (A) (right and left).

- c. Temporarily install the fairing assembly (8) to the head pipe installation holes (B) (right and left), as shown in Fig. 10, with two flange bolts (11) 8 x 14.

Note: Take care, when installing the fairing assembly (8) on the head pipe as shown in Fig. 10-b, so that it will not bite harnesses, hoses or cables.

- d. Temporarily install the fairing assembly (8) to the installation hole (C) on

the LH down tube joint part with the color LH stay rear (20) and the flange bolt (45) 8 x 80, as shown in Fig. 10.

- e. Temporarily install the fairing assembly (8) on the RH down tube, as shown in Fig. 10-a, with the bolt cowl stay setting (12), the plate cowl stay setting (13), the bracket RH fairing side stay (14), the two flange nuts (16) 6 mm and the flange bolt (15) 8 x 18.
- f. Temporarily install the fairing assembly (8) on the RH of the installation hole (A), as shown in Fig. 10-c, with the harness clip (60) and the flange bolt (74) 8 x 16, and clip the main harness.
- g. Temporarily install the fairing assembly (8) on the LH of the installation hole (A), as shown in Fig. 10-d, with the wire clip (59) and the flange bolt (74) 8 x 16. Then, clip the throttle cable and the choke cable.
- h. Permanently tighten all the bolts.

Note: Tighten the bolts to their respectively specified torques.

Fig. 10

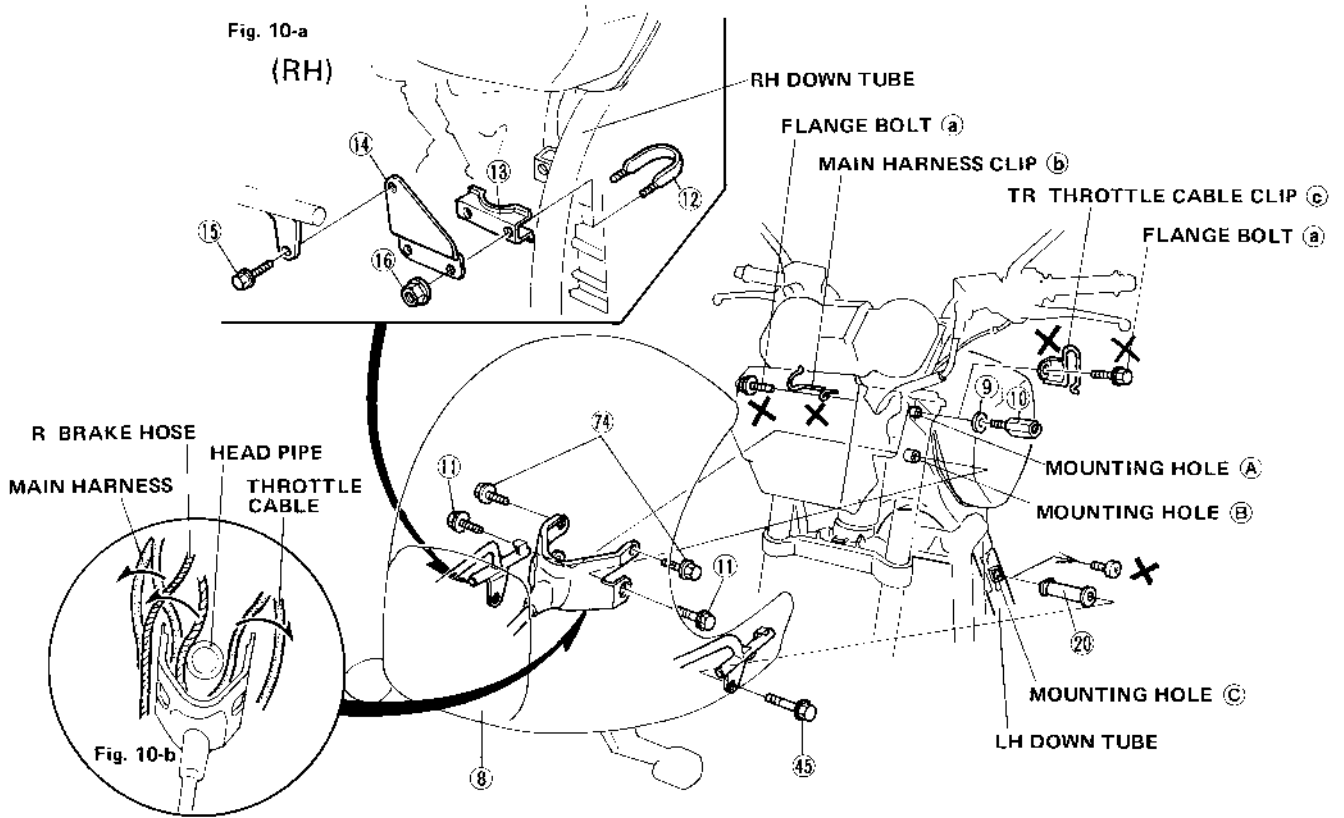

Fig. 10-c.  
(RH)

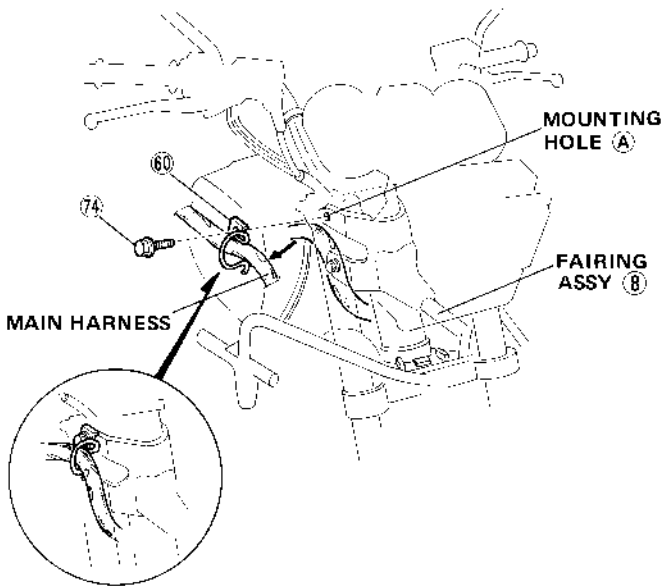
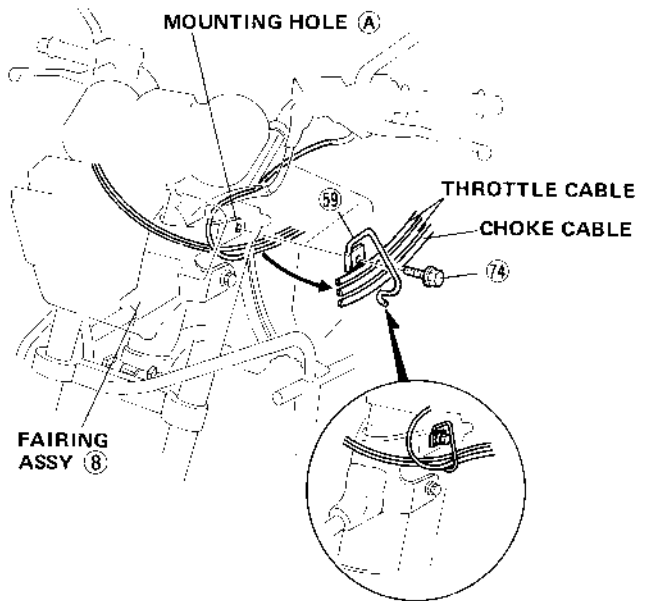

Fig. 10-d  
(LH)



### 11) Connection of the harnesses

- a. Fix the sub-wire harness ② on the fairing assembly ⑧ of the installation hole ⑤ with the band (black) ⑥③ as shown in Fig. 11, and connect it with the fairing harness.

Note: When installing the sub-wire harness ② with the band, move the steering wheel left and right to avoid excessive tension.

Fig. 11

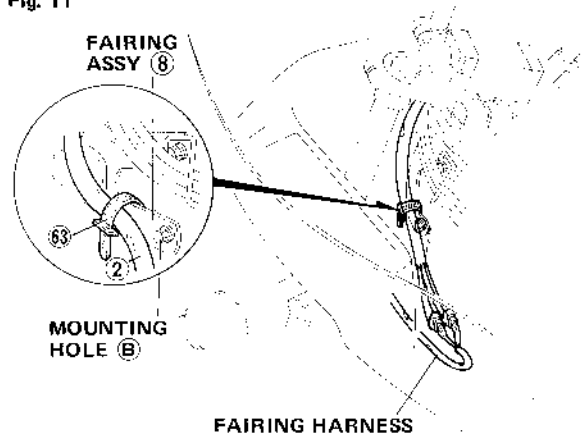

### 12) Installation of the horn assembly

- a. Remove the upper flange bolts (a) on the R/L front engine hanger brackets and install the horn R/L brackets (57) and (58) each with the flange bolt (66) 8 x 22, as shown in Fig. 12.
- b. Install the horn assemblies on the horn R/L brackets each with the flange (a) as shown in Fig. 12.

Note: Tighten the bolts to their specified torque.

- c. Connect the horn harness from the fairing assembly to the horn assembly as shown in Fig. 12, and fix them to the fairing assembly and the R/L down tubes with two bands (62) (aluminum) each.

Fig. 12

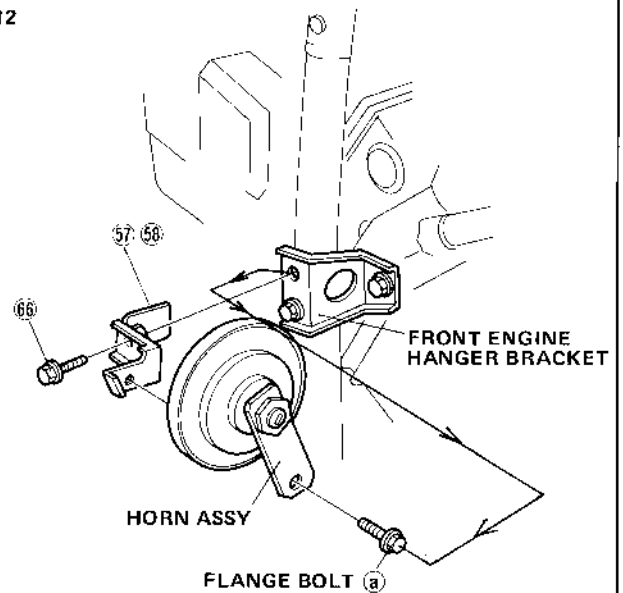

(RH)

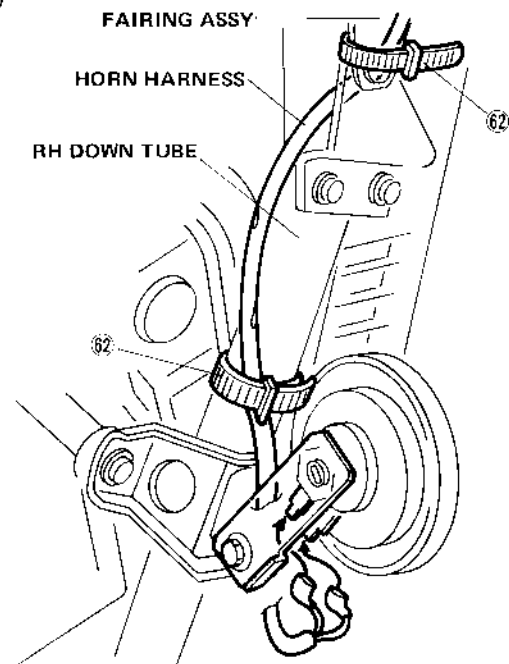

(LH)

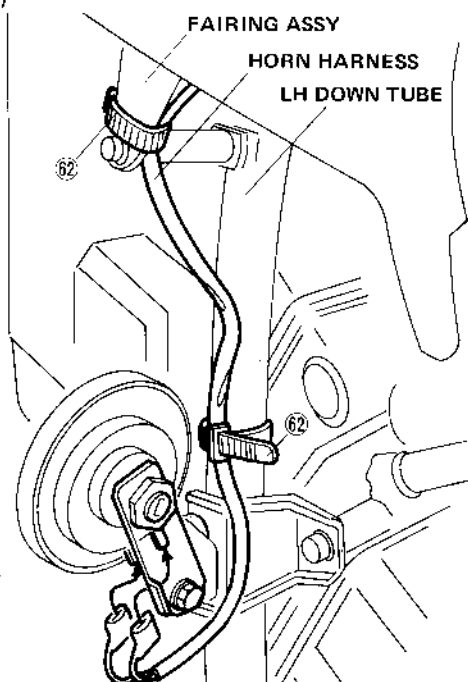

### 13) Installation of the R/L leg sheets

- a. Remove the R/L pocket of the fairing assembly. As shown in Fig. 13-a, remove the R/L washer nuts (a) 6 mm and the R/L flange bolts (b) 6 x 28 on the rear part of the turn signal stay, and install the R/L leg shield front brackets (28) and (29).
- b. Install the R/L leg shields (21) and (22) to the R/L installation holes (A) of the fairing assembly (8) each with the collar (18) (6 mm in diameter and 3.5 mm in length, black), the screw (17) 6 x 16 and the cap (19), temporarily.
- c. Temporarily install the R/L leg shields (21) and (22) to the R/L installation holes (B) of the fairing assembly (8), as shown in Fig. 13, each with the collar (46) (6 mm in diameter, 8 mm in length, black), the leg shield fitting screw (17) 6 x 14, and the leg shield cap (19).

- d. Assemble, as shown in Fig. 13-b, the leg shield rubber (64) to each of the R/L leg shield brackets (26) and (27).
- e. As shown in Fig. 13, install the leg shield stay band (51) to each of the R/L down tube, hook the R/L leg shield brackets (26) and (27), temporarily tighten them each with the special bolt (50) 6 x 16, and temporarily install the R/L leg shields (21) and (22) on the R/L leg shield brackets (26) and (27) each with two cap nuts (24) 6 mm, two special bolts (65) 6 x 22 and two collar (47) (6 mm in diameter, 13 mm in length, black).
- f. Permanently tighten all the bolts, screws and nuts.

Note: Tighten the bolts, screws and nuts to their respectively specified torques.

Fig. 13

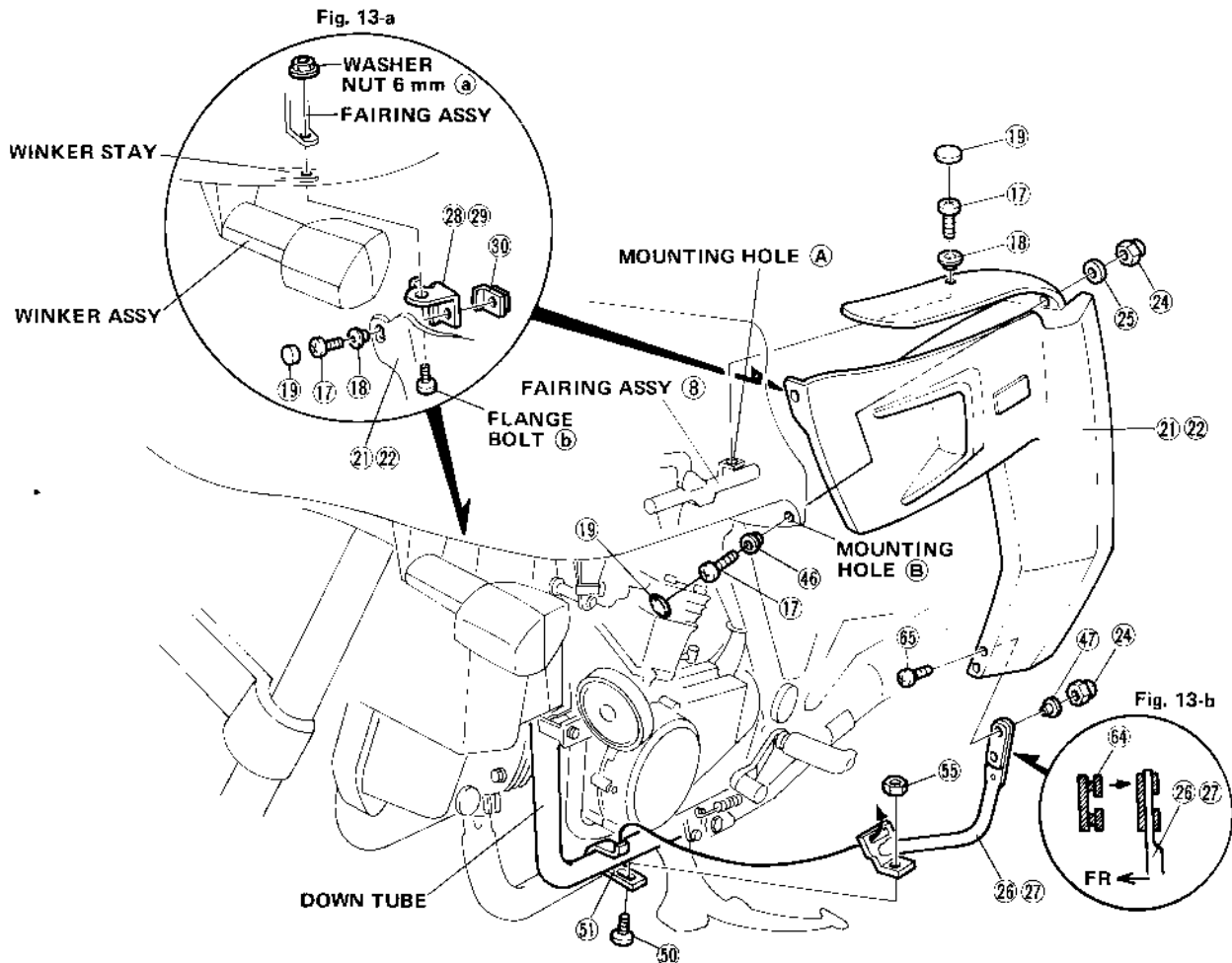

**NOTE:** Tighten the bolts to the specified torque.

14) Attach the caution labels as follows.

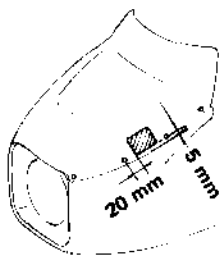
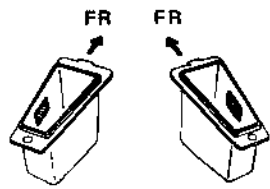
NAME	ILLUSTRATION
<b>WINDSHIELD CAUTION LABEL</b>	 <p style="text-align: center;">Fig. 14</p>
<b>FAIRING POCKET CAUTION LABEL</b>	 <p style="text-align: center;">Fig. 15</p>

15) Remove and mirrors from the handlebar.

16) Remove the headlight shield and adjust the headlight aiming.

17) Connect the battery ground cable to the negative battery terminal. Reinstall the side covers.

18) The weight of the fairing: 19 kg-2.5 kg  
(weight removed) = 16.5 kg assembly

Fig. 16

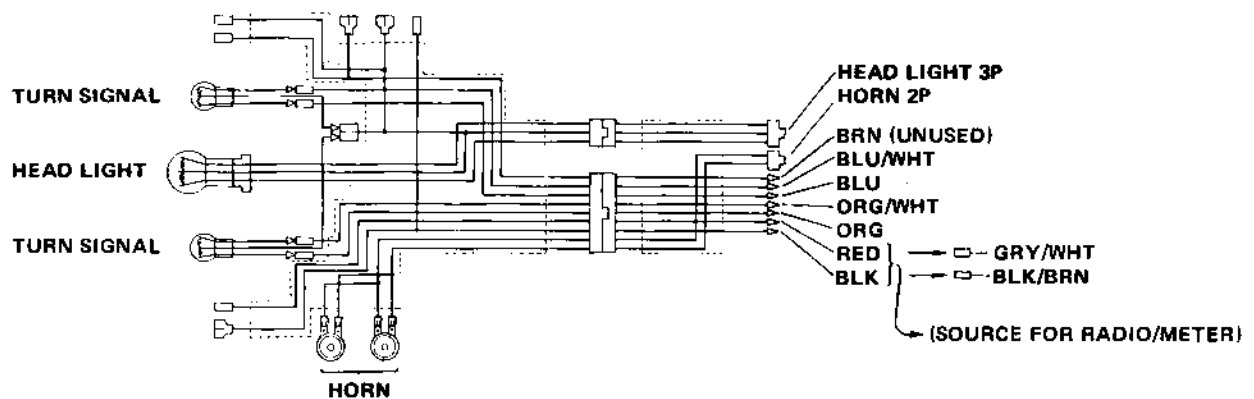

## PRE-DELIVERY SERVICE CHECK LIST

NOTE: Check all items listed on the following Pre-delivery Service Check List. Refer to Owner's manual or shop manual for specifications and detailed procedures. Always test ride the unit to make sure that it is functioning properly.

- Check the handlebar lever position.
- Check the brake cable routing.
- Adjust mirrors.
- Check choke operation and adjust idle speed.
- Check throttle grip free play, cable routing, and operation in all steering positions.
- Check tire pressure.
- Check operation and air pressure of front suspension.
- Inspect electrical components for proper operation and adjustment:
  - Headlight: Adjust high and low beam aim, and check high beam pilot light.
  - Turn signals.
  - Horn.
  - Engine stop switch.
  - Starter.
  - Instrument, flasher, oil pressure, headlight and neutral indicator lights.
- Check security of all nuts, bolts, and other fasteners.
- Check to ensure all applicable recall and product update campaigns are complied with.
- TEST RIDE: Check performance, handling, and operation:
  - Acceleration: Smoothness, etc.
  - Cruising: Smoothness, etc.
  - Handling: Stability and cornering.
  - Brakes: Smoothness and stopping power.
  - Idling: Smoothness, throttle response, return to idle.
  - Recheck idle speed after 10 minutes of stop and go driving.
  - Speedometer and Tachometer: Proper operation.
  - Upon completion of test ride, check for fuel, oil, or coolant leaks.

## RULES FOR SAFER RIDING

### WARNING

- Fairing pockets are for lightweight items. Do not carry more than 5 lbs in each pocket.
- Load weight equally in both pockets to minimize imbalance.
- Review Loading and Accessories before loading.
- Follow all safety notes and precautions described in the Owner's Manual.
- The weight of the accessory is shown below:

Weight added to motorcycle	16.5 kg (36.4 lbs)
----------------------------	--------------------

## HANDLING PRECAUTIONS

### Fairing Pockets

To remove the left pocket lid ①, turn the knob ② clockwise and pull up the lid.

Fig. 17

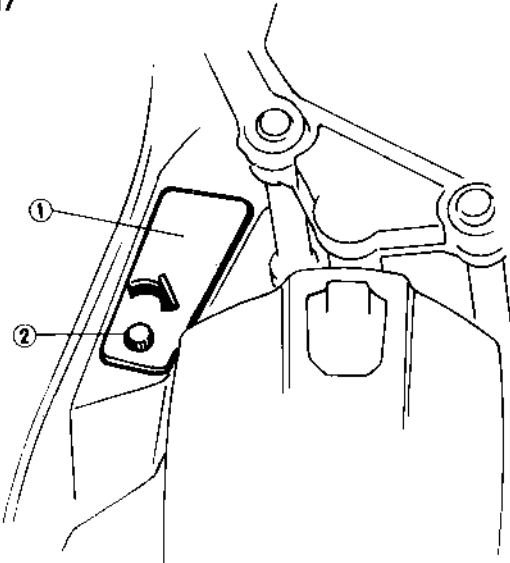

To remove the right pocket lid ③, insert the key ④, turn it clockwise and pull up the lid.

Fig. 18

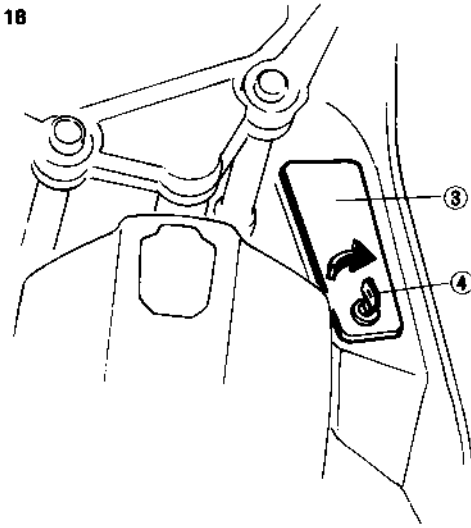

When washing your motorcycle, be careful not to flood this area with water.

To attach either pocket lid, align slot in front edge of lid with lug in pocket; push rear end of lid down until it snaps shut.

### Headlight Beam Adjustment

The headlight beam can be raised or lowered by turning the vertical beam adjusting knob ①. Obey local laws and regulations.

**WARNING**

- Do not adjust the headlight beam while riding the motorcycle. Keep both hands on the handlebars while riding.

Fig. 19

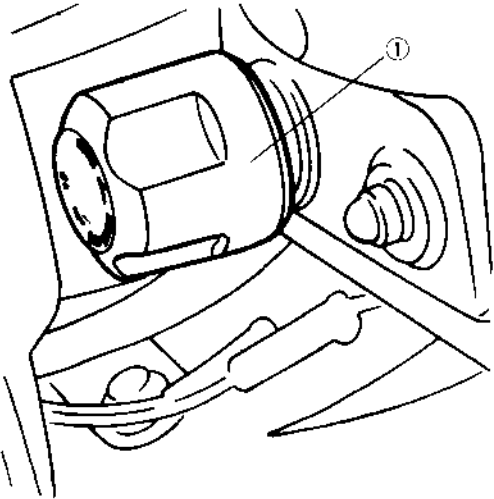

**HANDLING OF THE LOUVER  
INSTALLED ON THE LEG SHIELD**

- The dial inside is for vertical adjustment.
- Horizontal adjustment with the louver itself.
- For cleaning of the duct in the leg shield, remove the lower rubber and wash inside the duct with water.

Fig. 20

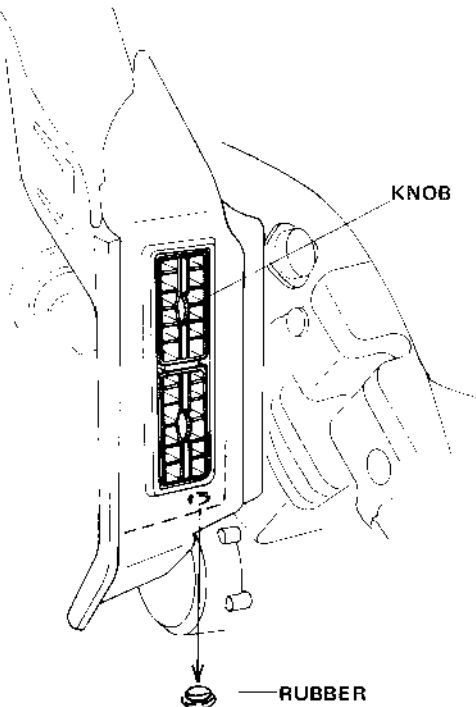

- Replacement of fuses  
Remove the two washer screws (71) and then remove the fuse cover (3) as shown in Fig. 21.  
Next, remove the fuse with the fuse puller installed inside the fuse cover.  
The fuse name is on the inner side.

Fig. 21

