

The concept, for this tabernacle chart, originally came from a reprint article, (6435-36), that was published after Pastor Charles Russell died.

The dates on this chart, are similar to the 1845 and the 1260, 2520 year patterns, in that they are also symmetrical about the midst of the years, (626.25 BC). This pattern has only 7 important dates on it.

### A Symbolic 25 Inch Cubit

The dates on this chart, are derived from the symbolic 25 inch cubit, that can be used to unlock the time features of God's plan. There were, originally, at least two different

cubits used in Biblical times. The first was 18 inches and the second was 21-22 inches. The 25 inch cubit, is the one that is described in Ezk 40:5, as being about a hands breadth larger than normal, (about 3 inches).

### 7000 Years Around the Tabernacle!

As an example of how this works, we see that the tabernacle is 100 by 50 cubits. From each gate post, to each corner, is 15 cubits. The total distance from the corner post of the first gate, all the way around the tabernacle, and back to the other gate post, is 280 cubits, (15+100+50+100+15 = 280). At 25 years per cubit, this is 25 x 280 or 7000 years!

### Curtains of linen and of goat hair.

5x4 = 20    20x2 = 40 YEARS

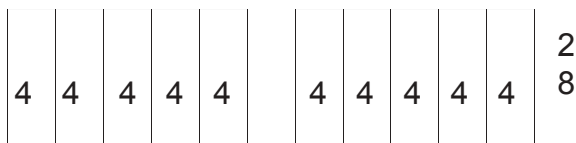

#### LINEN CURTAINS Ex 26:1-6, 30:8-10

The curtains that covered the tabernacle building have some interesting dimensions at 25 inches per year.

Total width of the ten curtains, is 40 cubits (40 x 25 = 1000).

Each curtain is 28 cubits long, and there are 10 curtains. Total length of all the curtains is 10 x 28 = 280 cubits, (280 x 25 = 7000 years).

Five curtains = (5 x 28 cu = 140 cu) (140 x 25 = 3500 yrs).

5x4 = 20    4x6 = 24    24+20= 44



#### CURTAINS OF GOAT HAIR EX 26:7-13,30:14-18

The curtains of goat hair, were different from the 10 linen curtains, in that there were 11 curtains and they were 30 cubits in length, instead of 28. The eleventh curtain was folded in half, in the front of the tabernacle. Without the eleventh curtain, the total was 40 cubits and again 40 x 25 = 1000.

The eleventh curtain that was folded in half, was 4 cubits wide, (4 x 25 = 100 years or Isaiah 65:20).

Another possible application of the folded curtain, is that each folded half is 2 cubits apiece, (2 cu x 25 = 50) (Jubilee)

## The Gate Posts Are the Dates

(1) If we call the first gate post the fall of Adam, the date for that post is 4126.25 BC.

(2) Going clockwise from there, the next important date that we arrive at, that corresponds to a post in the fence, is 3126.25 BC or the end of Adam's first day. This was the 1000 yr day, within which Adam was to die, at the age of 930.

(3) The original reprint article, placed the third date, 1251.25 BC, on the corner with a Judge named Jair. This interpretation has since had some doubt cast upon it, because this time period falls in the 450 yr. space of the Judges, which is uncertain as to its exact chronological make up.

The other possibility is a Judge named Jephthan, (Judges 12:6). Jephthan and his daughter make an excellent picture of our Lord and the church, since he consecrates her to the Lord, as a virgin for life. We think that Jephthan is the correct choice for this corner. We have to admit uncertainty, because this is the period of Judges, which is bridged only by Paul's

statement, regarding the 450 years. **The choice should be a type of Christ, since he is on the opposite corner from Christ's birth!**

(4) The fourth date is 626.25 BC, the midst of the years, which is the same central date, on the 1845 and 1260-2520 charts.

(5) The fifth date, is 1.25 BC, Oct, 2 BC, confirming the date of our Lords birth!

(6) The sixth date, is three-fourth of the way down the side, and is 1873.75 AD. This is the date of our Lords second presence. He is the second Adam, who is going to restore all back to perfection by the end of the 1000 year millennium. This date is also found on the 1260-2520 dominion chart.

(7) At the seventh and last date, we arrive back at the other gate post, 2873.75 AD, exactly 7000 years after we started out. This completes the cycle and shows that what Adam lost in the garden, will be restored exactly 7000 years later, at the end of the seventh day!

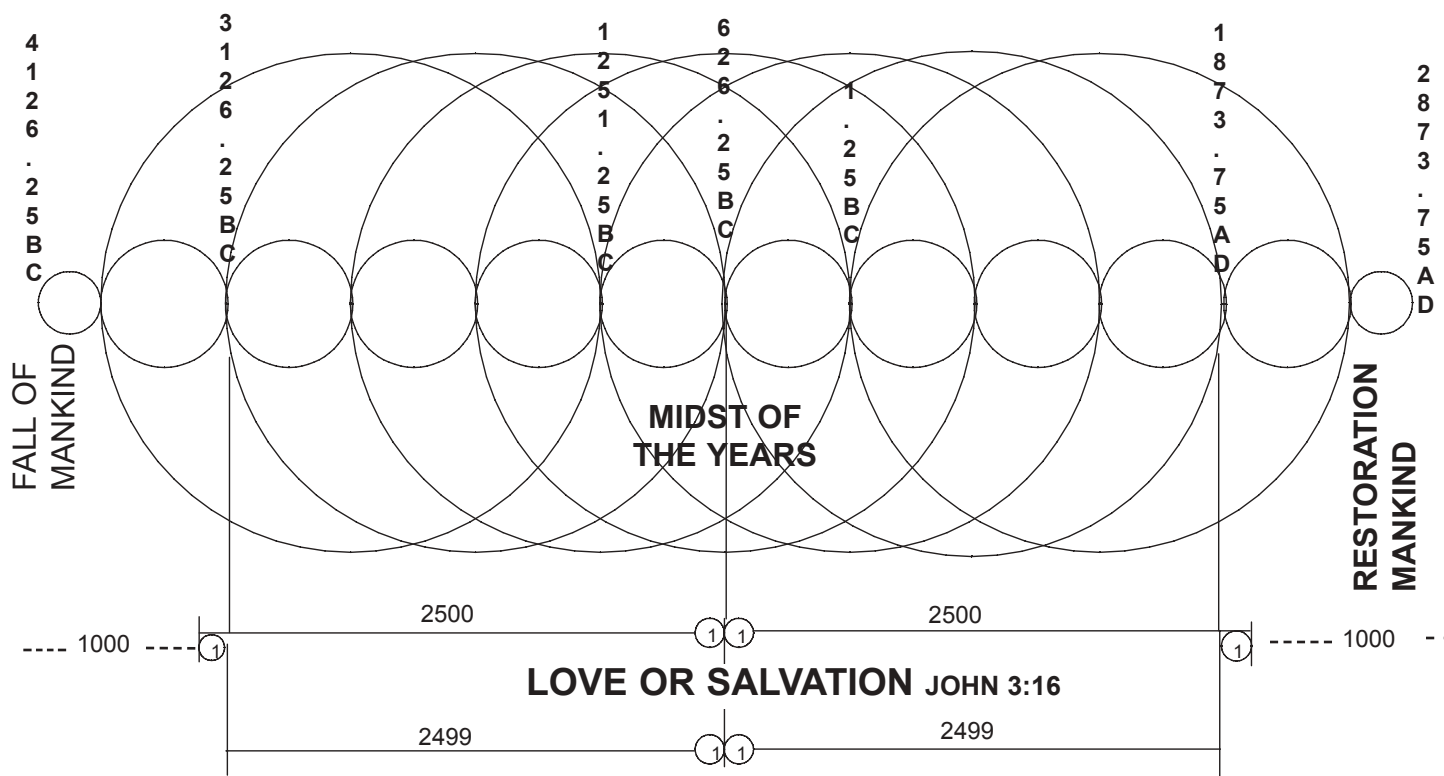

## The Circles Come from the Tabernacle Post Locations

If we redraw the dates that we find around the tabernacle fence, and place them in a repeating circular pattern like in the 1845 and the 1260-2520 year chart, this is what results. This circular line diagram, shows that the Jubilee cycle, is also part of a pattern, that is symmetrical about the midst of the years.

What Adam lost, is being pointed out, as what will be restored by the Jubilee, in the kingdom. Remember that Jesus said "For the son of man has come to restore what was lost Matt 18:11". The first man, Adam, forfeited his life during his 1000 yr day, but the second Adam, Christ, will use his day to give life to all mankind, who will accept it! God, through his love, made restitution possible, and for that reason, the attribute of love is shown by this chart. See "the 2nd volume, "Studies in the Scriptures", chapter 6, The earths great Jubilee.

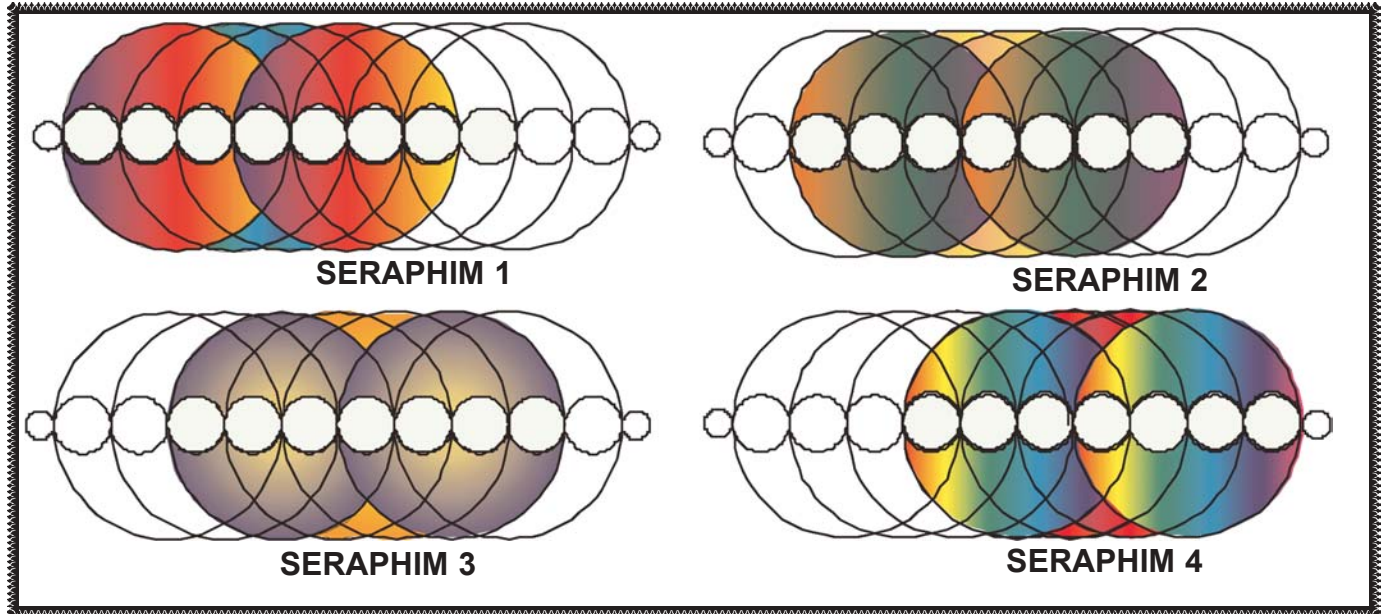

**Isa 6:2 Above him were seraphs, each with six wings: With two wings they covered their faces, with two they covered their feet, and with two they were flying.**

The 4 Seraphim from Isa 6:2, are similar to the ones found in the Ezekiel account, except that these have 6 wings apiece. Even though the scriptures don't say, we assume 4 Seraphim, because the other visions have four.

The wings are similar to Ezekiel's vision, but because this one has seven circles of 2500 years, and the Ezekiel account, only had 6 circles of 1845 years, we wind up with an extra pair of wings tucked in behind the other two pair, making six, just as Isaiah described. We have shaded these in differently, to make them easier to see.

### The 2500 Jubilee Picture

The fact that the anti-typical Jubilee started in Oct 1874, and will complete its work in Oct 2874, does not mean the full benefits of restitution were here in 1874. The world has only received fore-gleamings of the full benefits, that are due later. The only resurrection to life has been to the church, (1878 AD), and not to the world. See the special explanation section starting on page 38, regarding the Jubilee and restitution.

If we look at what happened in an actual Jubilee year, the beginning of that year, was started by blowing the feast of trumpets only in the temple, on the first of the month, Tishri. No one received any release from debt or servitude, until the 10 th of Tishri, when the Jubilee trumpet was blown throughout the entire land. Then the people were gathered together and a release was proclaimed to all, (Lev 25:28-55).

### The 1874 AD Jubilee Message

The same thing has been true at this end of the age, in that the Jubilee trumpet has been blowing since 1874, and the church has been proclaiming the message of the kingdom to all who will hear it. It's not possible for the world to get their full

release, until they are in the kingdom, and then not completely until the end of the 1000 years. Full restitution to the world will not come until the church is completed, and then the world will be restored back to Adamic perfection and health, by the end of the kingdom. The trumpet is blown on the 10 th of the month, and ten, in the Bible, shows earthly completeness.

### Coals of Fire Represent Ransom

The coals of fire, off the altar, mentioned in Isaiah 6:6-7, are the same coals of fire, we see in Ezekiel 10:2, 6-7, Rev 8:5, and they represent the ransom doctrine. In Isaiah's situation, it cleansed him from his iniquity, but in Ezekiel chapter 9-10 and in Rev chapter 8, the coals were cast over the city for judgment.

For anyone is in opposition to God's plan and the ransom, such as the false church system, these coals are part of a destructive process that will cleanse the world of its iniquity and sin. All things that are not built on the foundation of Christ, will not be able to stand, and will be completely removed, 1 Cor 3:11-15, Heb12:25-29.

The prophet says, in Hab 3:2, that God's work fills him with fear. **This word fear, is Strong's word #3372, which means reverence.** Reverence means to regard with high respect or awe. After seeing his plan reflected in these patterns, we can echo the prophets sentiments, in that God's work does fill us with great reverence and awe!

### God is Answering Hab Prayer

There is no doubt in our our mind, that God is answering Habakkuk's prayer, to a greater extent, than even he could have imagined! **The time will soon come, when all those who are in their graves will hear his voice and will be restored to health and life (John 5:25).**

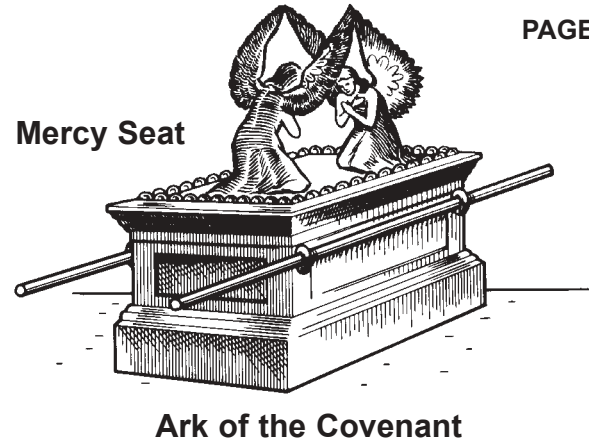
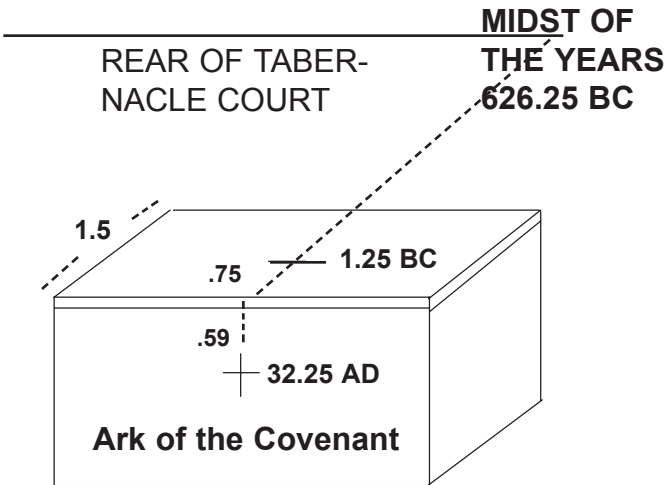

**LEVITICUS 16:14** And he shall take of the blood of the bullock, and sprinkle it with his finger upon the mercy seat eastward; and before the mercy seat shall he sprinkle of the blood with his finger seven times. **15** Then shall he kill the goat of the sin offering, that is for the people, and bring his blood within the veil, and do with that blood as he did with the blood of the bullock, and sprinkle it upon the mercy seat, and before the mercy seat:

### The Birth of Our Lord

Contrary to common historical thought, we believe that our Lord was born 1.25 BC or Oct 2 BC, and he was crucified 32.25 Ad or April of the year 33 AD. Using those dates, if you measure from the back of the tabernacle fence, at the midst of the years (626.25 BC), to the center of the mercy seat, you will find that the distance is 25 cubits. See page 30 for full view of tabernacle. Converting this into years, at 25 years per cubit, we get 625 years. Adding 625 years to 626.25 BC, gives you 1.25 BC. **His birth date therefore falls exactly between the Cherubs, in the center of the mercy seat!** This confirms that 1.25 BC, is the correct date for our Lords birth.

### Our Lords Ministry Reaches to the Eastern Face

If we take the time that our Lord spent on the earth (33.5 years), and we convert this into cubits, we get 1.34 cubits (33.5 divided by 25 = 1.34 cubits). Extending a line this length, from the birth of Christ, on the center of the mercy seat, across the top and then down to the eastern face of the ark, 1.34 cubits, brings you to April of 33 AD. This would then be .75 cu across the mercy seat, and down the face of the ark .59 cu.

The eastern side of the ark, is the side that you would face upon coming into the most holy. Its very likely that the high priest sprinkled the blood, starting on top of the mercy seat, and then towards the front, in an eastward direction. The path of the cubits points to where our Lord Jesus laid down his life for us in 33 AD. This is exactly where the high priest put the blood on the day of atonement.

### Seven Times For the Church

To sprinkle the blood 7 times before the mercy seat, was to

sprinkle it on the eastern front of the ark, where it could run down to the earth. That this is on the face of the ark, and not directly on the ground, is shown by the meaning of the word "upon", (*Strong's word # 6440*), which means face, forefront, front, etc., implying the front face of the mercy seat. That this sprinkling was done 7 times, shows the completeness of Christ's sacrifice for the church. The blood of the bullock was paid for himself and his house hold, at the first advent.

### Seven Times For the World

That the goat's blood was also sprinkled seven times, seems to show that when the church is complete, nothing more will be needed for the people of the world.

That the bullock was for himself, as well as for his household, is at first puzzling, since Christ was perfect and did not need ransoming. If we remember that Christ needed to be tested and to prove himself to the heavenly Father, we can then see that offering the bullock for himself, in symbol showed that he had done everything faithfully and without fail. The household, of course represents the church, who needed to be covered for their imperfections and who also need to prove themselves.

The world is waiting, for the time that all the members will have become part of the body of Christ. At that time the blood will be applied, for "all" the people (the goats blood Lev 16:15-16).

### The Cherubs Fly to Bless the World

Once the blood of the goat is applied, the two Cherubs will no longer be blocking the way to life, but will then be able to fly forth to bless all the world. In the next age, the rest of the world will be grafted into the nation of Israel, and all will receive the blessings. "Then *all* Israel shall be saved, as it says" (Rom 11:26)!

**BRAZEN ALTER**

EX 27:1 38:1

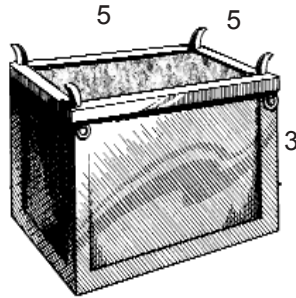

TOP 20  
 BOT 20  
 END 6  
 END 6  

---

 52

**MERCY SEAT**

EX 25:17 37:6



2.5  
 2.5  
 1.5  
 1.5  

---

 8

**TABLE OF SHOWBREAD**

EX 25:23, 37:10

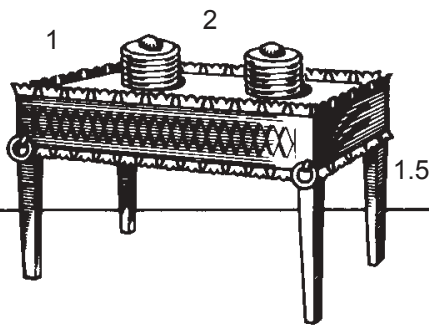

TOP 6  
 BOT 6  
 1.5  
 1.5  
 1.5  
 1.5  

---

 18

**ARK OF THE COVENANT**

EX 25:10, 37:1

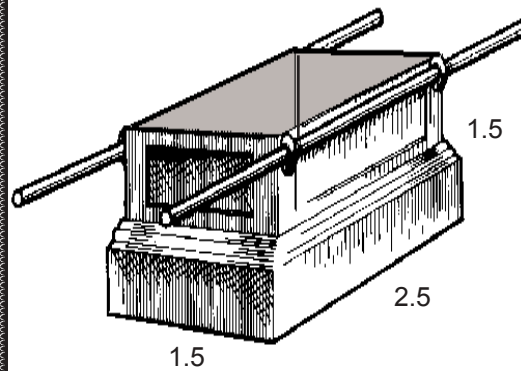

TOP 8  
 BOT 8  
 1.5  
 1.5  
 1.5  
 1.5  

---

 22

**THE TABLE OF SHEW-BREAD**

Total cubits above

Altar	52
Mercy Seat	8
Table of	
Show Bread	18
Ark Cov	22
	<hr/>
	100

**INCENSE ALTAR**

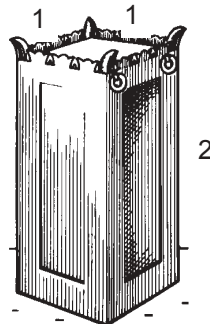

The 4 vertical are 2 cubits apiece.  
 The top is 4 cubits as is the bottom.

Two vertical of one face = 4 cu.  
 4 sides of top = 4 cu  
 4 sides of bottom = 4 cu

4 x 25 = 100 years

This is the 100 years of Isaiah 65:20

**2500 Jubilee in the Furniture**

If we add up all the dimensions of the brazen altar, the ark of the covenant, the mercy seat, and the table of show bread, we will find that they all total up to 100 cubits, ( 25 x 100 = 2500 years or the Jubilee).

**Dimensions of the Incense Altar = 100**

The only piece of furniture not used in that calculation, is the incense altar. Taking the incense altar by itself, we find that the top and the bottom, add up to 4 cubits. Any two vertical add up to 4 cubits. 4 x 25 = 100 cubits or the 100 years of Isaiah 65:20.

**The Brazen Altar = 1000**

If we take the top and the bottom of the brazen altar, the dimensions add up to 40 cubits, 40 x 25 = 1000 yrs. Looking at these numbers, we can see that the eventual restitution of all mankind, is being shown in the dimensions of the tabernacle furniture,when it's looked at together, Acts 3:19

We find represented in the tabernacle furniture, the 2500 Jubilee cycle, pointing to the restitution of all things, the 1000 year day in which mankind will be restored, and the fact that all will have at least 100 yrs to hear and to accept the kingdom.

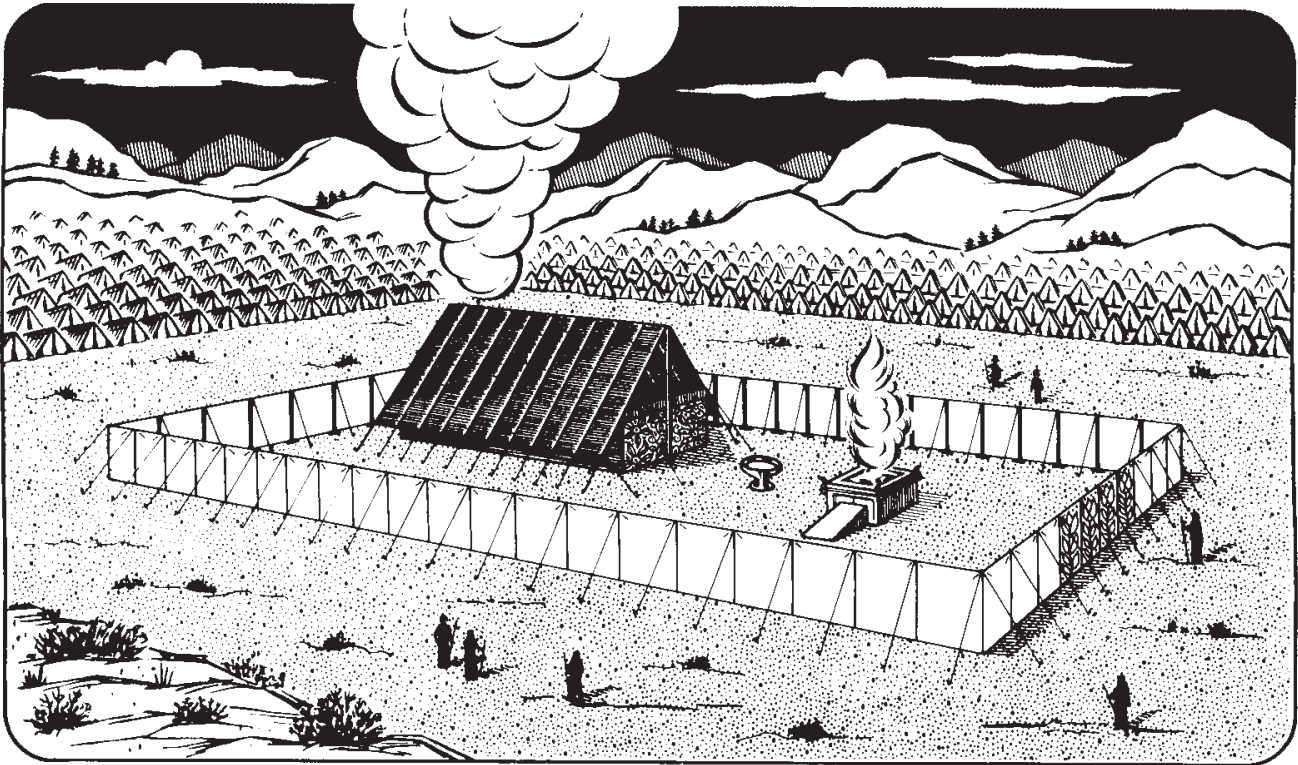

### Dimensions of the Most Holy = 1000 yr

The dimensions of any perimeter of the most holy are  $10+10+10+10 = 40$  which represents 1000 years ( $40 \times 25 = 1000$ ). The sum of any two lengths of a side wall of the holy, are  $20+20 = 40$ .

### The Altar Adds up to 1000 yr

The perimeter of the top and the bottom of the altar adds up to 40 cubits  $40 \times 25 = 1000$  yrs.

The sum of the length of the first vail of the holy plus the ceiling and the second vail of the most holy makes 40 ( $10+20+10$ ).  $40 \times 25 = 1000$  yrs.

### Dimensions of Most Holy = 6000 yr

All of the dimensions of the 6 walls of the most holy taken together add up to  $6 \times 40$  or 240 cubits. ( $240 \times 25 = 6000$  years). This is taking the measurements of each wall as if they were separate panels with 4 sides apiece.

If we add the line dimensions of the holy and most holy together, taking them as separate panels, we get 40 for an end + 80 for the lengths of the holy, 40 for the front wall of the most holy, 40 for the lengths of the most holy and 40 for the back wall ( $40+80+40+40+40 = 240$ ) ( $240 \times 25 = 6000$  yrs.

### The 2500 Year Jubilee is Represented

If you measure from the midst of the years at the center of the back of the tabernacle straight to the front gate without

going around the outside you get 100 cubits ( $100 \times 25 = 2500$ ). Not only is this the 2500 yrs of the Jubilee but if you add this number to the date at the center of the back of the tabernacle fence you get the date of our Lords second presence ( $626.25 \text{ BC} + 2500 = 1873.75 \text{ AD}$ ).

### A Year Per Cubit?

For example, we could get some interesting numbers at a year per cubit if we look at the dimensions of the buildings and the furniture, but again to save space, we are not going to do that except for the following example.

The altar in the court which represents Christ's sacrifice has some interesting diagonals. See the picture on the previous page. It was  $5 \times 5 \times 3$ . **The diagonals of the top are almost exactly 7 cubits (7.071).** At a year per cubit a half of this length is 3.5 yrs or the time our Lord spent in his ministry. Seven is the length of the last week of the 70 weeks Dan 9:24-27.

In some places its possible to mix together both methods of a yr. per cubit and 25 years per cubit but we are only going to do this where its necessary to gain an important lesson.

### More to the Story!

In the following pages we do not claim to have fully explained or even found all of the features associated with the different chronological cycles or cubits. God has designed into his plan much more complexity and detail than we can put into these pages.